

# BOELUBE 70307

Multi Use Medium Blue Paste  
High performance Lubricant

**BOELUBE®**



A BOEING DEVELOPED LUBRICANT



BOELUBE® 70307 Paste is non-toxic, non-irritating, environmentally safer synthetic lubricant for minimum quantity lubrication (MQL) application.

**TYPICAL PROPERTIES** ■■■

Physical State : Paste  
Color : Blue  
Melt Range : ~90-110F (32-43C)  
Density : ~ 0.84 g/cm<sup>3</sup> @ 25 C  
VOC Content : Non-volatile (< 0.1%)

**PRODUCT BENEFITS** ■■■

Superior Lubricity.  
100% active product.  
Non-Hazardous.  
Shelf life indefinite under ambient conditions.

**Applications**

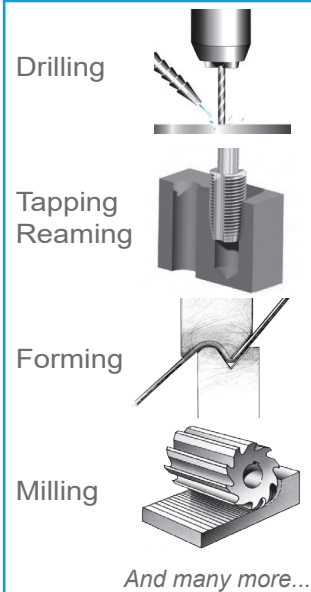

**CONTAINERS** ■■■



70307-02  
(2 oz - 57 g)



70307-L  
(4 oz - 113 g)



70307-12  
(12 oz - 340 g)



70307-05  
(35 lb - 16 kg)

**MATERIALS** ■■■

- |   |  |   |   |
|---|--|---|---|
| <input checked="" type="checkbox"/> Stainless steel | <input checked="" type="checkbox"/> Wood     | <input checked="" type="checkbox"/> CFRP        | <input checked="" type="checkbox"/> Alloy     |
| <input type="checkbox"/> Polymer                    | <input checked="" type="checkbox"/> Aluminum | <input checked="" type="checkbox"/> Glass fiber | <input type="checkbox"/> Kevlar               |
| <input checked="" type="checkbox"/> Copper          | <input checked="" type="checkbox"/> Titanium | <input type="checkbox"/> Resin                  | <input checked="" type="checkbox"/> Composite |

**Certifications**



**ABOUT BOELUBE PRODUCTS** ■■■



- Petroleum-free
- Silicone-free
- Biodegradable
- Chemically stable
- Sulfur-free
- Paraffin wax-free
- Non-corrosive
- Non-flammable
- Phosphorus-free
- Halogen-free
- Non-irritating
- Environmentally safer
- Used in aerospace and other manufacturing industries



**The Orelube Corporation**  
Specialty Industrial Lubricants Since 1958

**The Orelube Corporation**  
20 Sawgrass Drive  
Bellport, NY 11713  
USA

Phone: +1 800.645.9124  
+1 631.205.9700  
Fax: +1 631.205.9797  
Website: [www.orelube.com](http://www.orelube.com)



**NSF-ISR**

Registered to ISO 9001

*Produced under license from Boeing Intellectual Property Licensing Company. Boelube® is among the trademarks owned by Boeing. These products represent a family of proprietary lubricants developed through Boeing manufacturing operations and lubricant experience. The Orelube Corporation holds an exclusive worldwide license from Boeing Intellectual Property Licensing Company to manufacture and market the Boelube® series of lubricants. All products produced by The Orelube Corporation bearing the Boelube® label are manufactured in strict accordance with, and are manufactured in strict accordance to comply with Boeing specifications.*